

HA10VSO Series Variable Displacement Pump



Product show and brief introduction

Open Circuit

Size 28...140
Series 31
Nominal Pressure 28 MPa
Peak pressure 35 MPa



Features

- Variable displacement axial piston pump of swashplate design for hydraulic open circuit systems
- Flow is proportional to drive speed and displacement. It can be infinitely varied by adjustment of the swashplate
- ISO mounting flange
- Flange connections to SAE metric
- 2 case drain ports
- Good suction characteristics
- Permissible continuous pressure 28 MPa
- Low noise level
- Long service life
- Axial and radial loading of drive shaft possible
- High power-weight ratio
- Wide range of controls
- Short response times
- Through drive option for multi-circuit system

Model Code

HA10VS	O	71	DR	/31	R	-P	P	A	12	N00
Axial piston unit	Type of operation	Size (mL/r)	Control device	Series	Direction of rotation	Seals	Shaft end	Mounting flange	Service line connections	Through drives
HA10VS: Variable swashplate design, for industrial applications Nominal pressure 28MPa, peak pressure 35MPa	O: Pump in open circuits	28	DR: Pressure control	31	(Viewed on shaft end)	P: NBR nitril~caoutchouc to DIN ISO 1629 (shaft seal in FKM)	See below	A: ISO 2-hole	12: Pressure port B, Suction port S (SAE ports at opposite sides Metric fixing thread)	See below
		45	DRG: Pressure control, remotely controlled		R: Clockwise					
		71	DFR: Pressure /flow control		L: Anti clockwise					
		100	DFR1: Pressure /flow control, without orifice in X-line							
		140								

Shaft end

Size		28	45	71	100	140
Parallel with key DIN6885	P	✓	✓	✓	✓	✓
Splined shaft SAE	S	7/8 "	1 "	1 1/4 "	1 1/2 "	1 3/4 "
Splined shaft SAE (higher through drive torque)	R	7/8 "	1 "	1 1/4 "	/	/

Through drives

Size		28	45	71	100	140
Without through drive	N00	✓	✓	✓	✓	✓
ISO 100,2-hole splined shaft 7/8 " 22-4 (SAE B) HA10VSO28(shaft S or R)	KB3	✓	/	✓	✓	✓
ISO 100,2-hole splined shaft 1 " 25-4 (SAE B-B) HA10VSO45(shaft S or R)	KB4	/	✓	✓	✓	✓
ISO 125,2-hole splined shaft 1 1/4 " 32-4 (SAE C) HA10VSO71(shaft S or R)	KB5	/	/	✓	✓	✓
ISO 125,2-hole splined shaft 1 1/2 " 38-4 (SAE C-C) HA10VSO100(shaft S)	KB6	/	/	/	✓	✓

✓ = available / = not available

- If a second Brueninghaus pump is to be fitted at factory then the two model codes must be linked with a "+" sign.
Model code 1st pump + Model code 2nd pump.
Ordering example: HA10VSO 100DR/31R-PPA12KB5 + HA10VSO 71DFR/31R-PSA12N00
- If a gear or radial piston pump is to be fitted at factory please consult us.

Fluid, Mechanical Displacement Limiter

● Hydraulic fluid

The HA10VSO variable displacement pump is suitable for use with mineral oil.

● Operating viscosity range

In order to obtain optimum efficiency and service life, we recommend that the operating viscosity (at operating temperature) be selected from within the range

$$v_{opt} = \text{operating viscosity } 16 \dots 36 \text{ mm}^2/\text{s}$$

Referred to the reservoir temperature (open circuit).

● Viscosity limits

The limiting values for viscosity are as follows:

$$v_{min} = 10 \text{ mm}^2/\text{s}$$

short term at a max. permissible case temp. of 90°C.

$$v_{max} = 1000 \text{ mm}^2/\text{s}$$

short term on cold start

● Temperature range (see selection diagram)

$$t_{min} = -25^\circ\text{C}$$

$$t_{max} = 90^\circ\text{C}$$

● Selection diagram

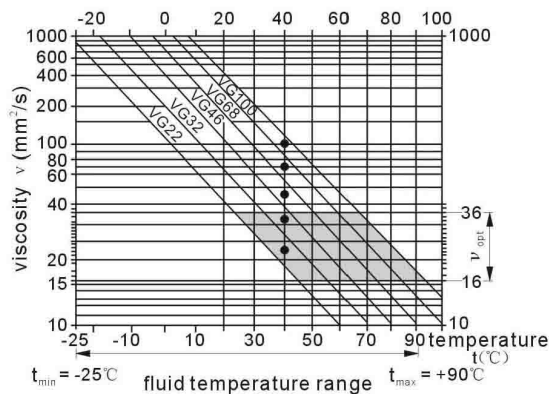

● Notes on the selection of the hydraulic fluid

In order to select the correct fluid, it is necessary to know the operating temperature in the tank (open loop) in relation to the ambient temperature.

The hydraulic fluid should be selected so that within the operating temperature range, the operating viscosity lies within the optimum range (v_{opt}) (see shaded section of the selection diagram). We recommend that the higher viscosity range should be chosen in each case.

Example: At an ambient temperature of $x^\circ\text{C}$ the operating temperature is 60°C . Within the operating viscosity range (v_{opt} ; shaded area), this corresponds to viscosity ranges VG46 or VG68; VG68 should be selected.

Important: The leakage oil (case drain oil) temperature is influenced by pressure and pump speed and is always higher than the tank temperature. However, at one point in the circuit the temperature may exceed 90°C .

If it is not possible to comply with the above conditions because of extreme operating parameters or high ambient temperatures please consult us.

● Filtration

The finer the filtration the better the cleanliness of the pressure fluid and the longer the life of the axial piston unit. To ensure the functioning of the axial piston unit a minimum cleanliness level of:

9 to NAS 1638

18/15 to ISO/DIS 4406 is necessary

if above mentioned grades cannot be maintained please consult supplier.

● High-speed-version

The size 140 is available in an optional high speed version. This version allows higher drive speeds at max. displacement (higher output flow) without affecting outside dimensions, see table on page 80.

● Mechanical displacement limiter

Mechanical displacement limiter is possible on the nonthru-drive model, N00 series but not for the model with thru-drive.

V_{gmax} : for sizes 28 to 140
setting range V_{gmax} to 50% V_{gmax} stepless

V_{gmin} : for sizes 100 and 140
setting range V_{gmin} to 50% V_{gmin} stepless

Technical Data

● Operating pressure range-inlet

Absolute pressure at port S

$P_{abs\ min}$ _____ 0.08 MPa
 $P_{abs\ max}$ _____ 3 MPa

● Operating pressure range-outlet

Pressure at port B

Nominal pressure P_N _____ 28 MPa
 Peak pressure P_{max} _____ 35 MPa

(Pressure data to DIN 24312)

Applications with intermittent operating pressures up to 31.5 MPa at 10% duty are permissible.

Limitation of pump output pressure spikes is possible with relief valve blocks mounted directly on flange connection.

● Case drain pressure

Maximum permissible pressure of leakage fluid (at port L, L₁);
 Maximum 0.05 MPa higher than the inlet pressure at port S,
 but no higher than 0.2 MPa absolute.

● Direction of through flow

S to B

● Table of values (theoretical values, without taking into account η_{mh} and η_v ; values rounded off)

Size		28	45	71	100	140
Displacement	$V_{g\ max}$ mL/r	28	45	71	100	140
Max. speed ¹⁾	at $V_{g\ max}$ $n_{o\ max}$ rpm	3000	2600	2200	2000	1800
Max. permitted speed (limit speed) with increased input pressure P_{abs} bzw. $V_g < V_{g\ max}$	$n_{o\ max}$ rpm	3600	3100	2600	2400	2100
Max. flow	at $n_{o\ max}$ $q_{v\ max}$ L/min	84	117	156	200	252
	at $n_E = 1500\ min^{-1}$ L/min	42	68	107	150	210
Max. power ($\Delta P = 28\ MPa$)	at $n_{o\ max}$ $P_{o\ max}$ kW	39	55	73	93	118
	at $n_E = 1500\ min^{-1}$ kW	20	32	50	70	98
Max. torque ($\Delta P = 28\ MPa$)	at $V_{g\ max}$ T_{max} Nm	125	200	316	445	623
Torque ($\Delta P = 10\ MPa$)	at $V_{g\ max}$ T Nm	45	72	113	159	223
Moment of inertia about drive axis	J kgm ²	0.0017	0.0033	0.0083	0.0167	0.0242
Case volume	L	0.7	1.0	1.6	2.2	3.0
Weight (without fluid)	m kg	15	12	33	45	60
Permissible loading of drive shaft: max. axial force	$F_{ax\ max}$ N	1000	1500	2400	4000	4800
Max. permissible radial force ²⁾	$F_{q\ max}$ N	1200	1500	1900	2300	2800

1) These values are valid for an absolute pressure of 0.1 MPa at the suction port S. By reducing the displacement or increasing the input pressure the speed can be increased as shown in the diagram.

2) Please consult us for higher radial forces.

● Determination of displacement

Flow $q_v = \frac{V_g \cdot n \cdot \eta_v}{1000}$ [L/min]

Torque $T = \frac{1.59 \cdot V_g \cdot \Delta P}{1000 \cdot \eta_{mh}} = \frac{V_g \cdot \Delta P}{20 \cdot \pi \cdot \eta_{mh}}$ [Nm]

Power $P = \frac{T \cdot n}{9549} = \frac{2 \pi \cdot T \cdot n}{60000} = \frac{q_v \cdot \Delta P}{600 \cdot \eta_t}$ [kW]

Determination of inlet pressure P_{abs} at suction port S or reduction of displacement for increasing speed.

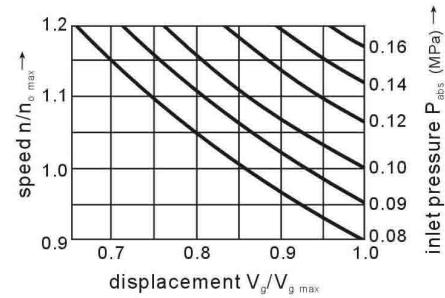

application of forces

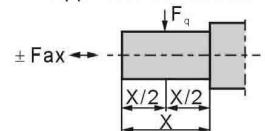

V_g = displacement (mL/r) per revolution
 ΔP = pressure differential (MPa)
 n = speed (rpm)
 η_v = volumetric efficiency
 η_{mh} = mechanical-hydraulic efficiency
 η_t = overall efficiency ($\eta_t = \eta_v \cdot \eta_{mh}$)

Installation Notes

Optional installation position. The pump housing must be filled with fluid during commissioning and remain full when operating. In order to attain the lowest noise level, all connections (suction, pressure, case drain ports) must be linked by flexible couplings to tank.

Avoid placing a check valve in the case drain line.

This may, however, be permissible in individual cases, after consultation with us.

1. Vertical installation (shaft end upwards)

The following installation conditions must be taken into account:

1.1. Arrangement in the reservoir

Before installation fill pump housing, keeping it in a horizontal position.

a) If the minimum fluid level is equal to or above the pump mounting face close port "L" plugged, leave ports "L₁" and "S" open; L₁ piped and recommendation S piped (see Fig. 1).

b) If the minimum fluid level is below the pump mounting face pipe port "L₁" and "S" according to Fig. 2.

Close port "L" with respect taking into consideration conditions in 1.2.1.

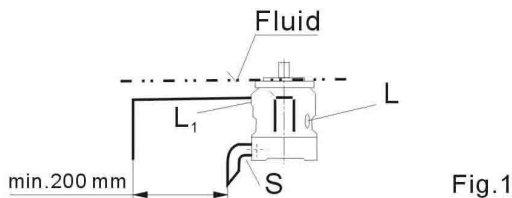

Fig. 1

1.2. Arrangement outside the reservoir

Before installation fill the pump housing, keeping it in a horizontal position. For mounting above reservoir see Fig. 2.

Limiting condition:

1.2.1. Minimum pump inlet pressure $P_{abs\ min} = 0.08\ MPa$ under both static and dynamic conditions.

Note: Avoid mounting above reservoir wherever possible in order to achieve a low noise level.

The permissible suction height h comes from the overall pressure loss, but may not be bigger than $h_{max} = 800\ mm$ (immersion depth $h_{t\ min} = 200\ mm$).

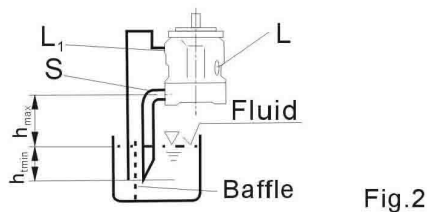

Fig. 2

Overall pressure loss $\Delta P_{tot} = \Delta P_1 + \Delta P_2 + \Delta P_3 \leq (1 - P_{abs\ min}) = 0.02\ MPa$

ΔP_1 : Pressure loss in pipe due to accelerating column of fluid

$$\Delta P_1 = \frac{\rho \cdot l \cdot dv}{dt} \cdot 10^{-6} \text{ (MPa)}$$

ρ = density (kg/m³)

l = pipe length (m)

dv/dt = rate of change in fluid velocity (m/s²)

ΔP_2 : Pressure loss due to static head

h = height (m)

$$\Delta P_2 = h \cdot \rho \cdot g \cdot 10^{-6} \text{ (MPa)}$$

ρ = density (kg/m³)

ΔP_3 : Line losses (elbows etc.)

g = gravity = 9.81 m/s²

2. Horizontal installation

The pump must be installed, so that "L" or "L₁" is at the top.

2.1. Arrangement in the reservoir

a) If the minimum fluid level is above the top of the pump, port "L₁" closed, "L" and "S" should remain open, L piped and recommendation S piped (see Fig. 3)

b) If the minimum fluid level is equal to or below the top of the pump, pipe ports "L" and possibly "S" as Fig. 4.; close port "L₁".

The conditions according to item 1.2.1.

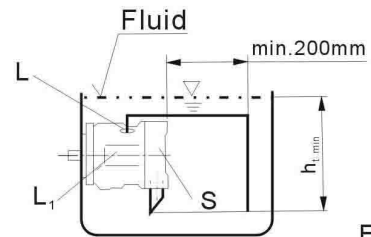

Fig. 3

2.2. Installation outside the reservoir

Fill the pump housing before commissioning. Pipe ports "S" and the higher port "L" or "L₁".

a) When mounting above the reservoir, see fig. 4. Conditions according to 1.2.1.

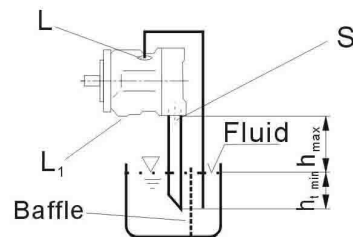

Fig. 4

b) Mounting below the reservoir
Pipe ports "L₁" and "S" according to Fig. 5, close port "L".

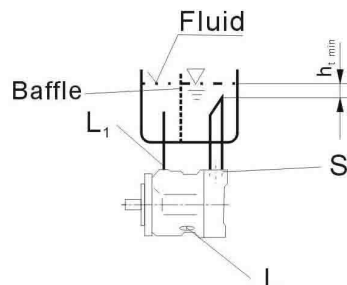
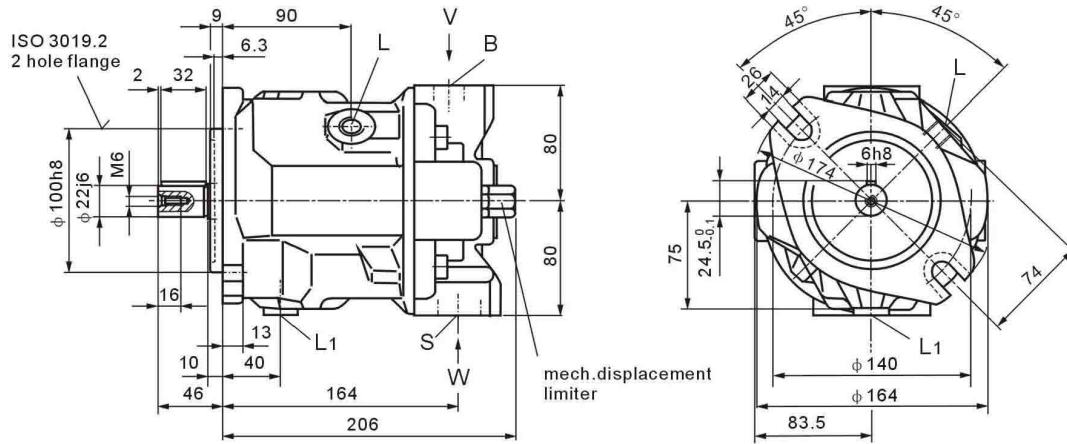

Fig. 5

Installation Dimensions

HA10VSO28※/31※-※A12N00(without control valves)

Shaft P



Shaft S

Shaft 22-4; (SAE B)
SAE J744 OCT 83

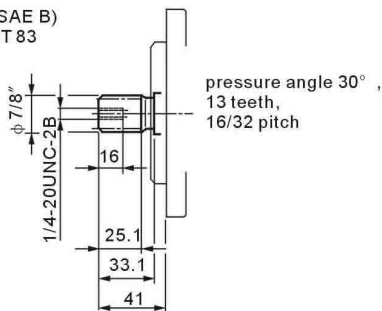

View W

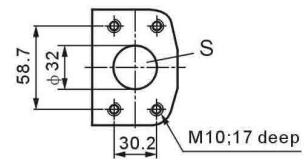

View V

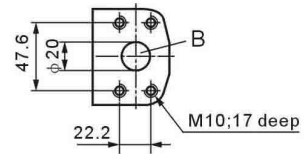

Shaft R

Shaft 22-4; (SAE B)
SAE J744 OCT 83

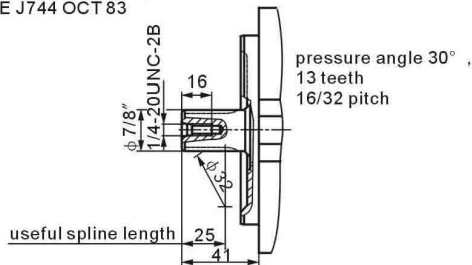

B	Pressure port	SAE 3/4"	(Standard pressure range)
S	Suction port	SAE 1 1/4"	(Standard pressure range)
L/L ₁	Case drain ports	M18 × 1.5	(L ₁ plugged at factory)

Installation Dimensions

HA10VSO45※/31※-※A12N00(without control valves)

Shaft P

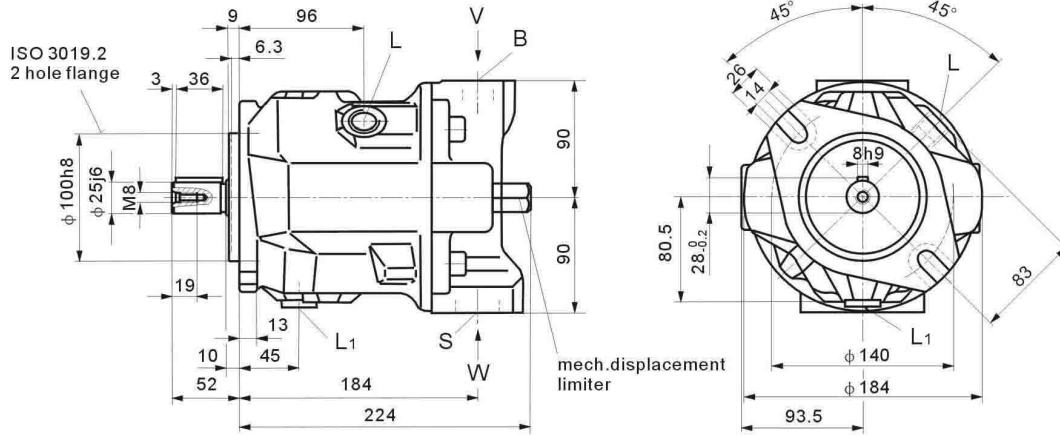

Shaft S

Shaft 25-4;(SAE B-B)
SAE J744 OCT 83

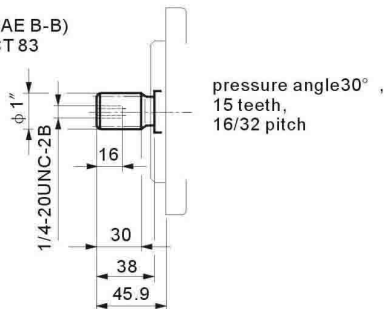

View W

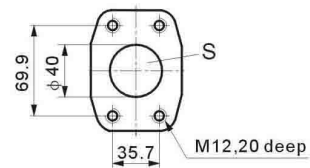

Shaft R

Shaft 25-4;(SAE B-B)
SAE J744 OCT 83

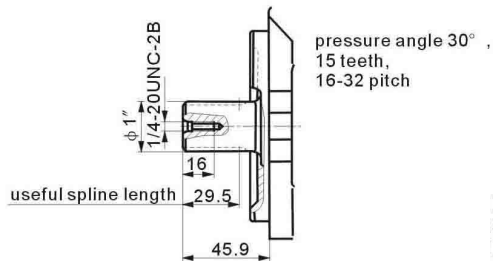

View V

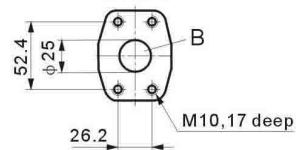

B	Pressure port	SAE 1"	(Standard pressure range)
S	Suction port	SAE 1 1/2"	(Standard pressure range)
L/L ₁	Case drain ports	M22 × 1.5	(L ₁ plugged factory)

Installation Dimensions

HA10VSO71*/31*/-*/A12N00(without control valves)

Shaft P

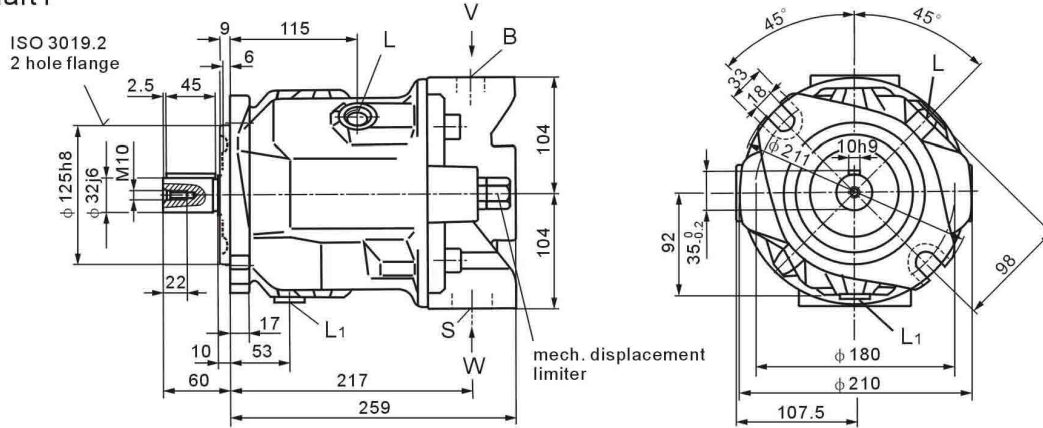

Shaft S

Shaft 32-4; (SAE C)
SAE J744 OCT 83

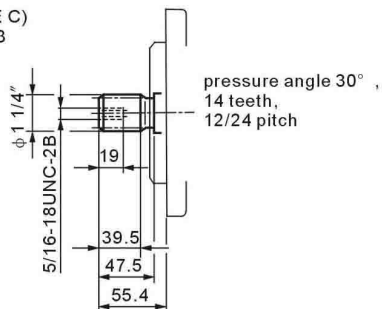

View W

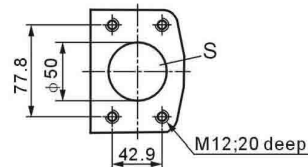

Shaft R

Shaft 32-4; (SAE C)
SAE J744 OCT 83

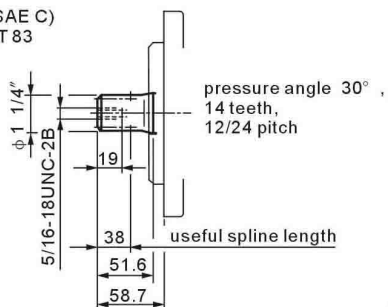

View V

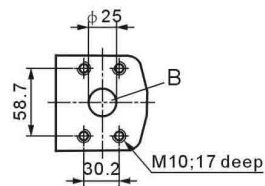

B	Pressure port	SAE 1"	(Standard pressure range)
S	Suction port	SAE 2"	(Standard pressure range)
L/L ₁	Case drain ports	M22 × 1.5	(L ₁ plugged at factory)

Installation Dimensions

HA10VSO100※/31※-※A12N00(without control valves)

Shaft P

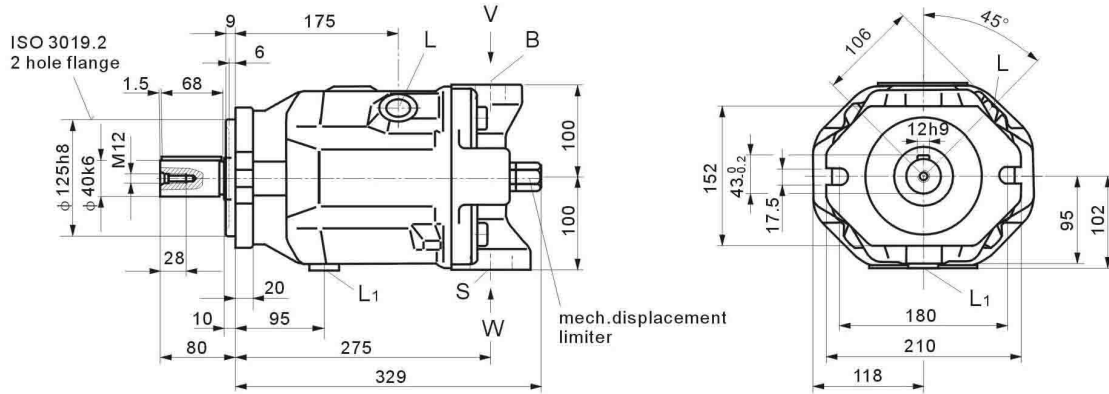

Shaft S

Shaft 38-4;(SAE C-C)
SAE J744 OCT 83

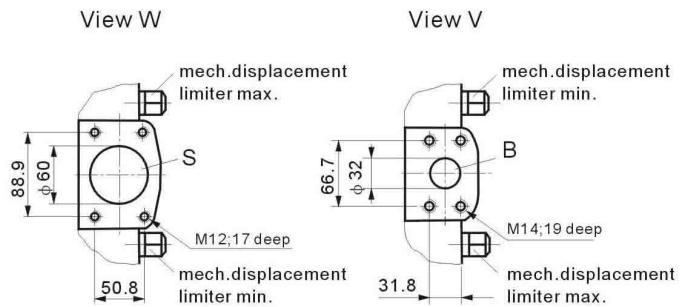
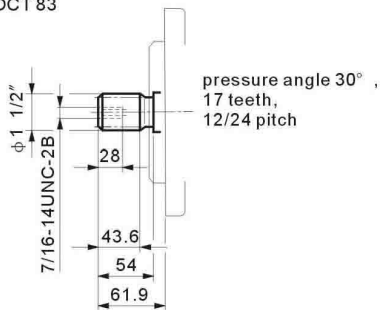

B	Pressure port	SAE 1 1/4"	(High pressure range)
S	Suction port	SAE 2 1/2"	(Standard pressure range)
L/L ₁	Case drain ports	M27 × 2	(L ₁ plugged at factory)

Installation Dimensions

HA10VSO140※/31※-※A12N00(without control valves)

Shaft P

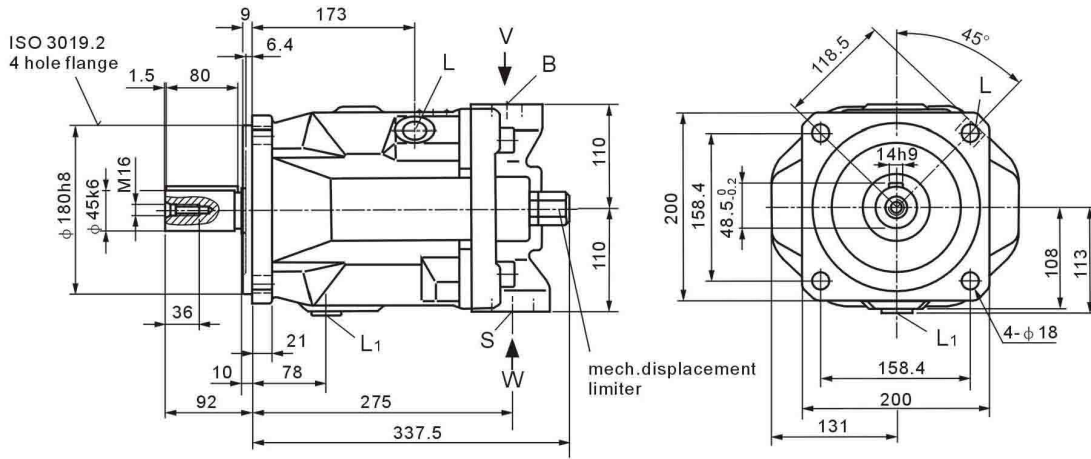

Shaft S

Shaft 44-4; (SAE D)
SAE J744 OCT 83

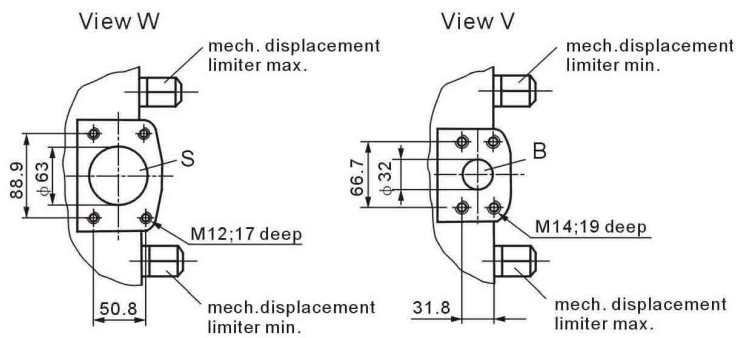
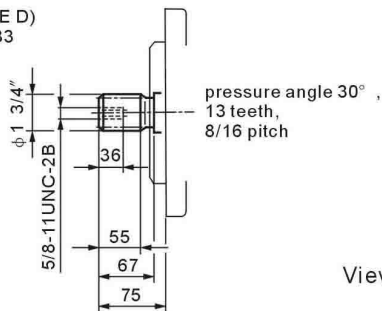

- | | | | |
|------------------|-----------------|------------|-------------------------------------|
| B | Pressure port | SAE 1 1/4" | (High pressure range) |
| S | Suction port | SAE 2 1/2" | (Standard pressure range) |
| L/L ₁ | Case drain port | M27 × 2 | (L ₁ plugged at factory) |

DR Pressure Control

The pressure controller serves to maintain a constant pressure in a hydraulic system within the control range of the pump. The pump therefore supplies only the amount of hydraulic fluid required by the system. Pressure may be steplessly set at the control valves.

● Static operating curve

(at $n_1=1500$ rpm; $t_{oil}=50^\circ\text{C}$)

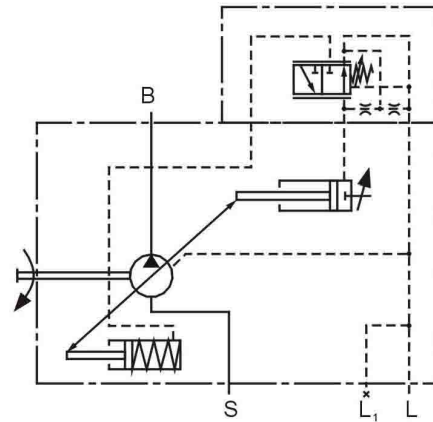
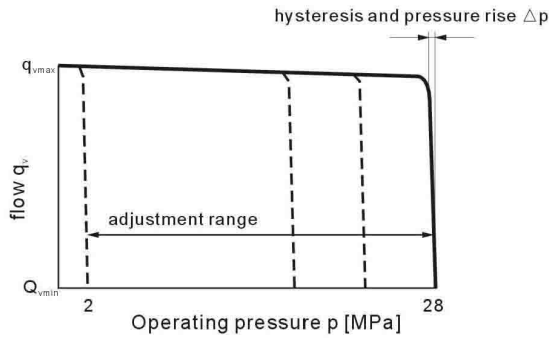

● Dynamic operating curves

The operating curves are mean values measured under test conditions with the unit mounted inside the tank.

Conditions: $n = 1500$ rpm
 $t_{oil} = 50^\circ\text{C}$
 Main relief set at 35 MPa

Load steps were obtained by suddenly opening and closing the pressure line with a pressure relief valve as load valve 1 m from the output flange of the pump.

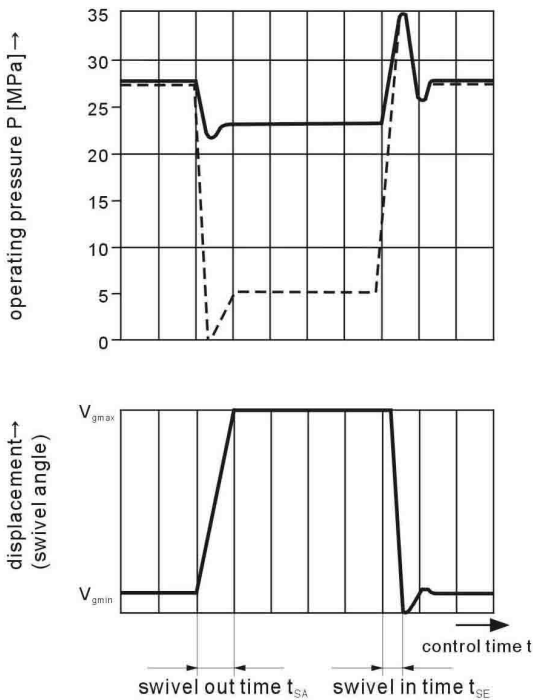

Ports

- B Pressure port
- S Suction port
- L, L₁ Case drain ports (L₁ plugged)

● Controller Data

Hysteresis and repetitive accuracy ΔP max. 0.3 MPa

Max. pressure rise

Size	28	45	71	100	140
ΔP MPa	0.4	0.6	0.8	1.0	1.2

Polit oil requirement Max. approx 3 L/min

● Control Times

Size	t_{SA} (ms)		
	again 5 MPa	again 22 MPa	again 28 MPa
28	60	30	20
45	80	40	20
71	100	50	25
100	125	90	30
140	130	110	30

Installation Dimensions

HA10VSO※DR/31R-※12N00

Sizes 28... 100

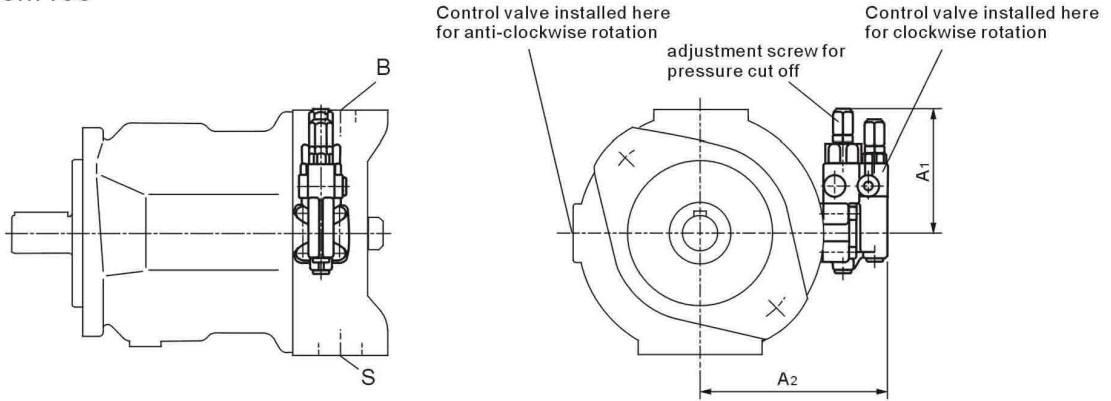

On sizes 28 to 100 the DFR valve used has the flow control spool blocked in the factory and is not tested.

Size 140

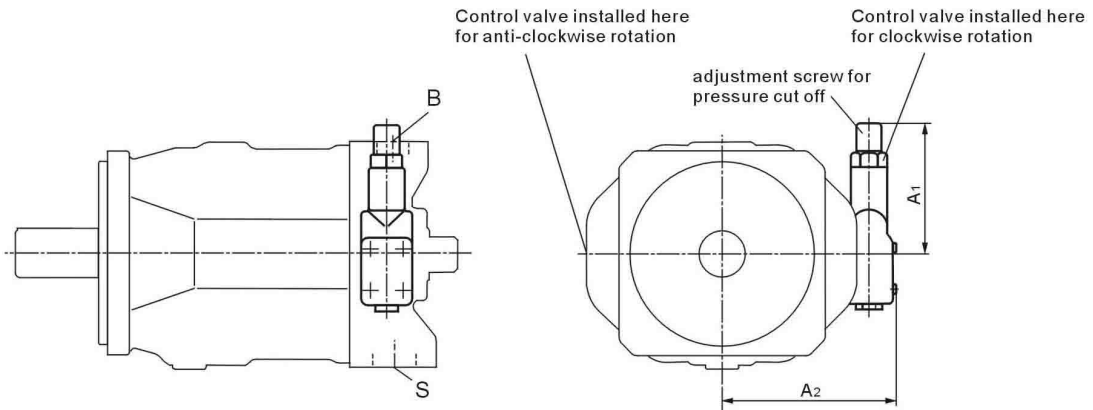

Size	A ₁	A ₂
28	109	136
45	106	146
71	106	160
100	106	165
140	127	169

DRG Pressure Controller, Remote Control

Function and equipment as for DR.

A pressure relief valve can be connected to port X for remote control applications; this is not included in the items supplied with the DRG control.

The standard pressure differential setting at the control valve is 2 MPa. A pilot oil flow of approx. 1.5 L/min is then used. If an other setting (range 1-2.2 Mpa) is required please indicate in clear text.

● Static Operating Curve

(at $n_1=1500$ rpm; $t_{oil}=50$ °C)

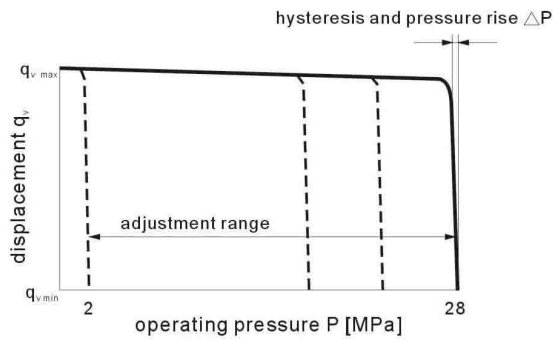

● Controller Data

Hysteresis ΔP _____ max. 0.3 MPa

Max. pressure rise

Size	28	45	71	100	140
ΔP MPa	0.4	0.6	0.8	1.0	1.2

Pilot oil requirement _____ approx. 4.5 L/min

Sizes 28...100

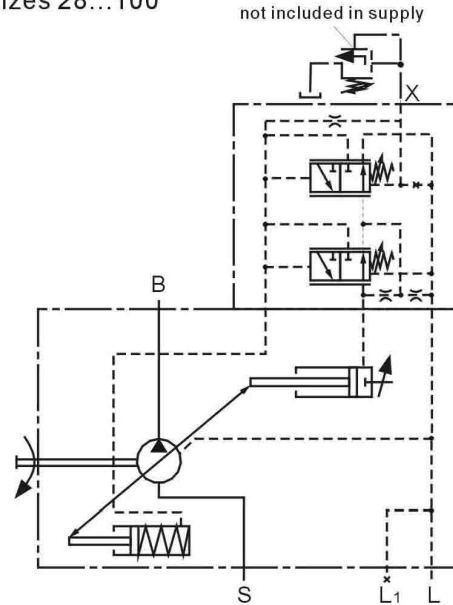

Size 140

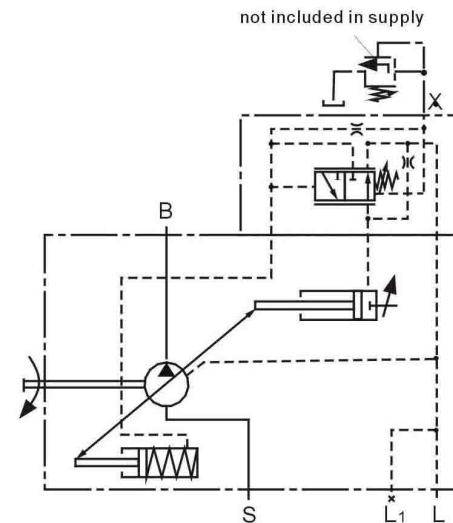

Ports

- B Pressure port
- S Suction port
- L, L₁ Case drain ports (L₁ plugged)
- X Pilot pressure port

Installation Dimensions

HA10VSO※DRG/31R-※12N00

Sizes 28... 100

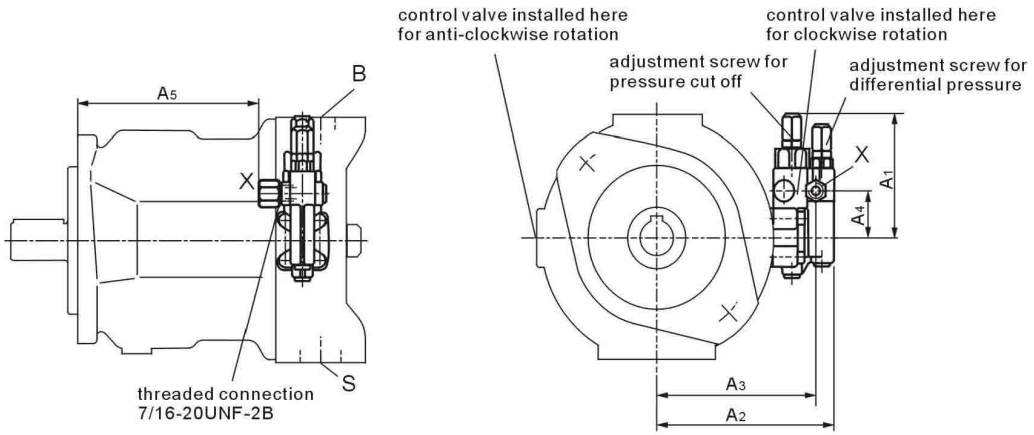

Size 140

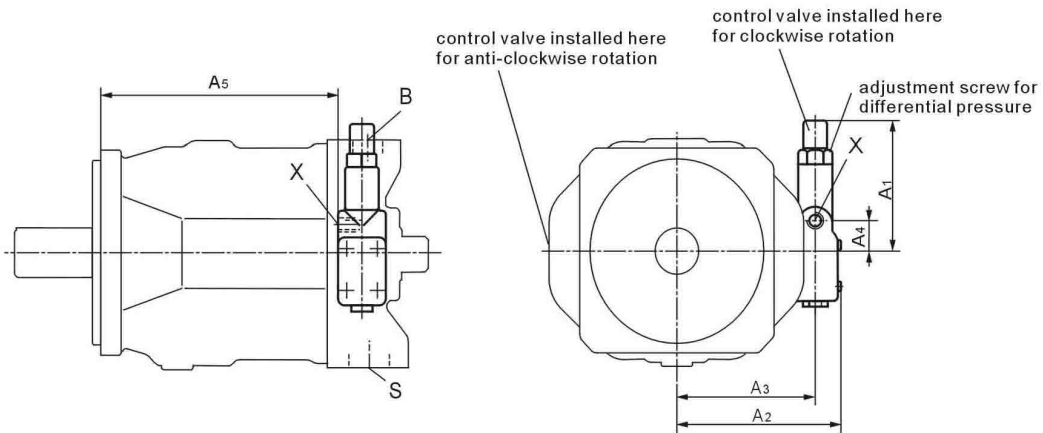

Size	A ₁	A ₂	A ₃	A ₄	A ₅	Port X
28	109	136	119	40	119	M14 × 1.5; 12 deep
45	106	146	129	40	134	M14 × 1.5; 12 deep
71	106	160	143	40	162	M14 × 1.5; 12 deep
100	106	165	148	40	229	M14 × 1.5; 12 deep
140	127	169	143	27	244	M14 × 1.5; 12 deep

with adaptor

without adaptor

DFR/DFR1 Pressure / Flow Control

In addition to the pressure control function, the pump flow may be varied by means of a differential pressure over an orifice or valvespool, installed in the service line. The pump flow is equal to the actual required flow by the actuator.

The DFR1-valve has no connection between X and the tank. For function of pressure control see pages 87/88.

● Static operating curve

(at $n_1=1500$ rpm; $t_{oil}=50^\circ\text{C}$)

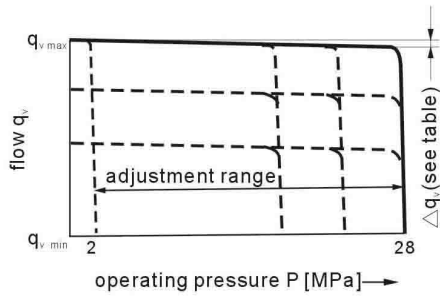

● Static operating curve at variable speed

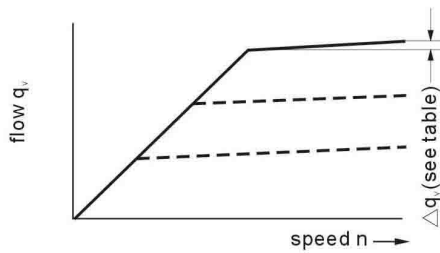

● Dynamic flow control operating curve

The operating curves are average values measured under test conditions with the unit mounted inside the tank.

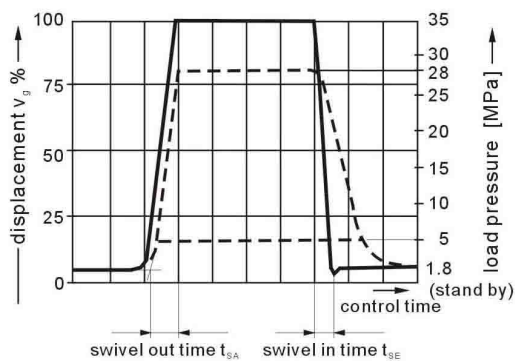

Size	t_{SA} (ms)	t_{SE} (ms)	t_{SE} (ms)
	stand by-28 MPa	28 MPa-stand by	5 MPa-stand by
28	40	20	40
45	50	25	50
71	60	30	60
100	120	60	120
140	130	60	130

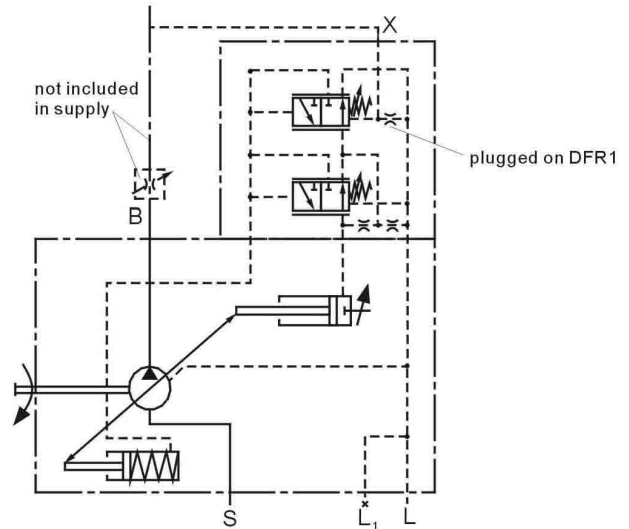

Ports

- B Pressure port
- S Suction port
- L, L₁ Case drain ports (L₁ plugged)
- X Pilot pressure port

● Differential Pressure ΔP

Adjustable between 1 and 2.2 MPa (higher valves on request).
Standard setting: 1.4 MPa. If a different setting is required please indicate in clear text.
When port X is unloaded to tank a "zerostroke pressure" of $P=1.8 \pm 0.2$ MPa (stand by) results (dependent on ΔP).

● Controller Data

Data pressure controller see page 87.
Max. Flow variation (hysteresis and increase) measured at drive speed $n=1500$ rpm

Size	28	45	71	100	140	
Δq_{vmax}	L/min	1.0	1.8	2.8	4.0	6.0

DFR pilot oil consumption _____ max. approx. 3...4.5 L/min

DFR1 pilot oil consumption _____ max. approx. 3 L/min

Installation Dimensions

HA10VSO*DFR/31R-*12N00
 HA10VSO*DFR1/31R-*12N00

Sizes 28...100

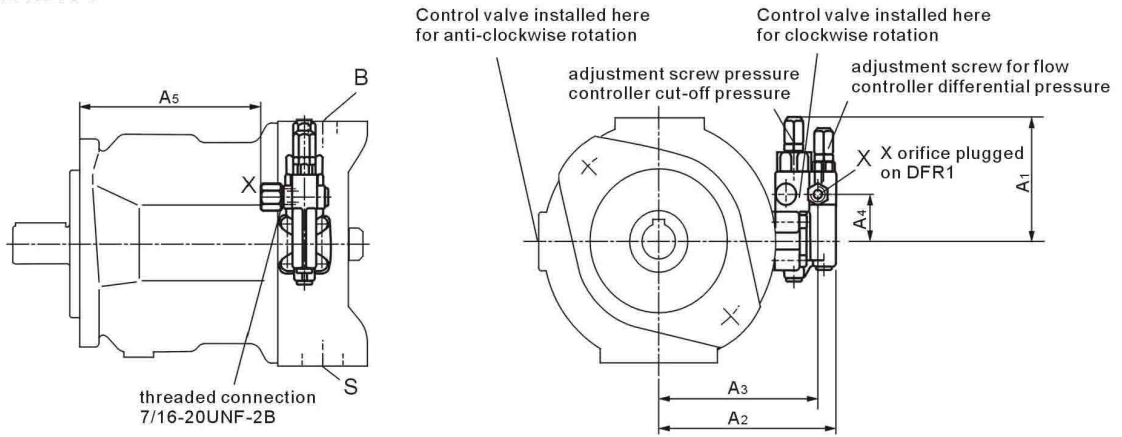

Size 140

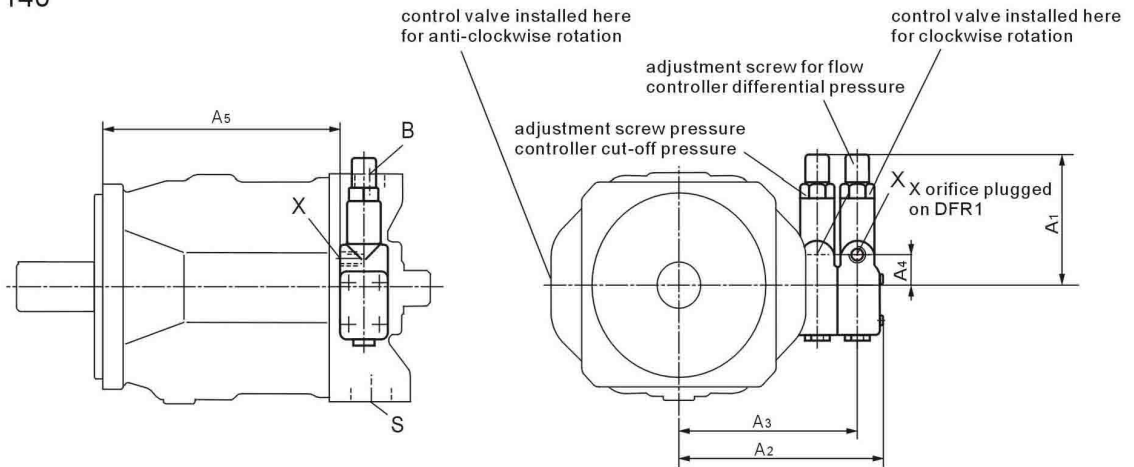

Size	A ₁	A ₂	A ₃	A ₄	A ₅	Port X	
28	109	136	119	40	119	M14 × 1.5; 12 deep	} with adaptor
45	106	146	129	40	134	M14 × 1.5; 12 deep	
71	106	160	143	40	162	M14 × 1.5; 12 deep	
100	106	165	148	40	229	M14 × 1.5; 12 deep	
140	127	209	183	27	244	M14 × 1.5; 12 deep	without adaptor

Through Drive

The HA10VSO pump can be supplied with through drive in accordance with the type code on page 78. The through drive version is designated by the code numbers (KB3-KB6).

If on other pumps are fitted by the manufacturer, the simple type designation is sufficient.

In this case, the delivery package comprises: Hub fixing screws, seal and, if necessary, an adaptor flange.

● Combination Pump

By building on further pumps it is possible to obtain independent circuits:

1. If the combination pump consists of 2 HA10VSO and if these are to be supplied assembled then the two order codes should be linked by means of a "+" sign.

Ordering example:

HA10VSO 71 DR/31 L -PPA12KB3+

HA10VSO 28 DR/31 L -PSA12N00

2. If a gear or radial piston pump is to be built on at the factory, please consult us.

● Maximum permissible input and through drive torque

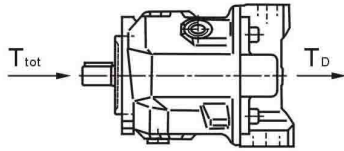

The split in torque between pump 1 and 2 is optional. The max. permissible input torque T_{tot} as well as the max. permissible through drive torque T_D may not be exceeded.

Size	28	45	71	100	140	
Max. permissible input torque at pump 1 with shaft "P"						
T_{tot}	Nm 137	200	439	857	1206	
Max. permissible through-drive torque	T_D	Nm 137	200	439	778	1206
	$T_{D \text{ keyed shaft}}$	Nm 112	179	283	398	557

Size	28	45	71	100	140	
Max. permissible input torque at pump 1 with shaft "S"						
T_{tot}	Nm 137	319	626	1104	1620	
Max. permissible through-drive torque	T_D	Nm 160	319	492	778	1266
	$T_{D \text{ keyed shaft}}$	Nm 112	179	283	398	557

Size	28	45	71	100	140	
Max. Permissible input torque at pump 1 with shaft "R"						
T_{tot}	Nm 225	400	644	-	-	
Max. permissible through-drive torque	T_D	Nm 176	365	548	-	-
	$T_{D \text{ keyed shaft}}$	Nm 112	179	283	-	-

Permissible moment of inertia

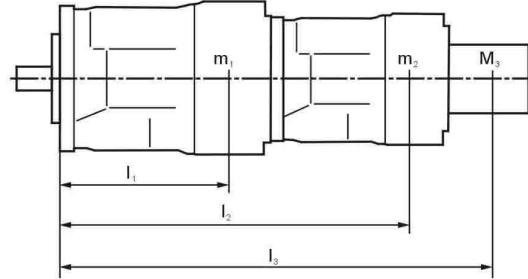

m_1, m_2, m_3 [kg] Pump mass

l_1, l_2, l_3 [mm] distance to center of gravity

$$T_m = (m_1 \cdot l_1 + m_2 \cdot l_2 + m_3 \cdot l_3) \cdot \frac{1}{102} \text{ [Nm]}$$

Size	28	45	71	100	140	
Permissible moment of inertia	T_m	Nm 880	1370	2160	3000	4500
Permissible moment of inertia at dynamic mass acceleration $10g \hat{=} 98.1 \text{ m/s}^2$	T_m	Nm 88	137	216	300	450
Mass	m_1	kg 15	21	33	45	60
To center of gravity	l_1	mm 110	130	150	160	160

T_{tot} = Max. permissible input torque at pump 1
 T_D = Max. permissible through-drive torque at through-drive to splined shaft
 $T_{D \text{ keyed shaft}}$ = Max. permissible through-drive torque at through-drive to keyed shaft

Installation Dimensions

HA10VSO+HA10VSO

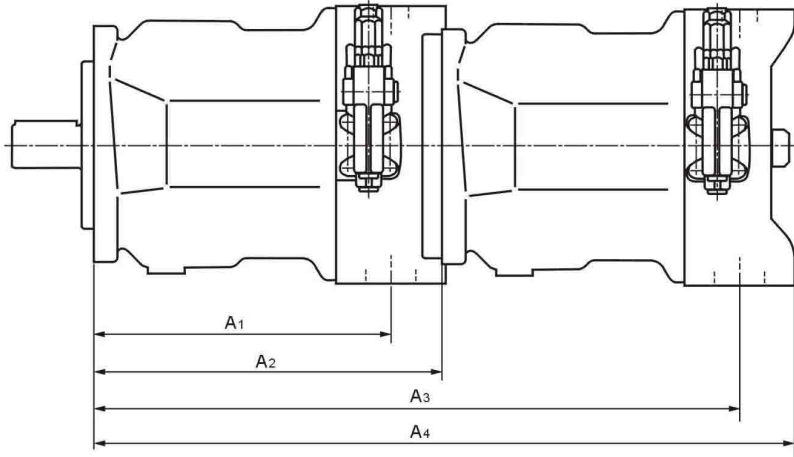

main p. built-on p.	HA10VSO 28				HA10VSO 45				HA10VSO 71				HA10VSO 100				HA10VSO 140			
	A1	A2	A3	A4	A1	A2	A3	A4	A1	A2	A3	A4	A1	A2	A3	A4	A1	A2	A3	A4
HA10VSO28	164	204	368.5	410	-	-	-	-	217	267	431.5	473	275	338	502.5	544	275	350	514	556
HA10VSO45	-	-	-	-	184	229	413	453	217	267	451	491	275	338	522	562	275	350	534	574
HA10VSO71	-	-	-	-	-	-	-	-	217	267	484	524	275	338	555	595	275	350	567	609
HA10VSO100	-	-	-	-	-	-	-	-	-	-	-	-	275	337	613	664	275	350	625	679

Installation Dimensions Through Drives KB3 And KB4

Flange ISO 100, 2-hole for built-on HA10VSO 28 (splined shaft S or R)

Order code KB3

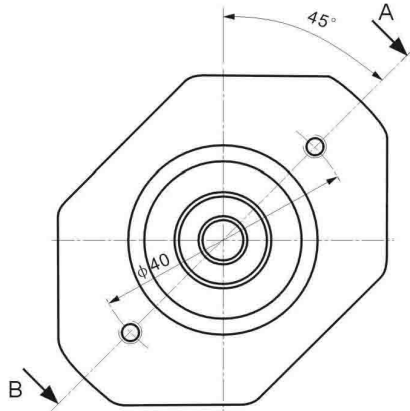

Size main pump	A ₁	A ₂	A ₃
28	204	19.2	14
71	267	16.5	18
100	338	17.6	18
140	350	18.2	24

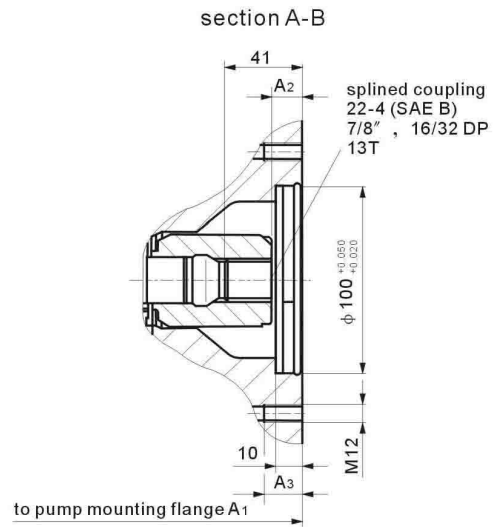

Flange ISO 100, 2-hole for built-on HA10VSO 45 (splined S or R)

Order code KB4

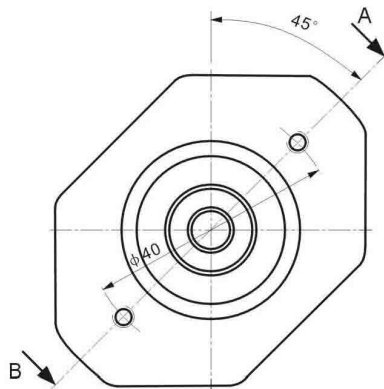

Size main pump	A ₁	A ₂	A ₃
45	229	17.2	14
71	267	17.2	18
100	338	18.2	20
140	350	18.2	24

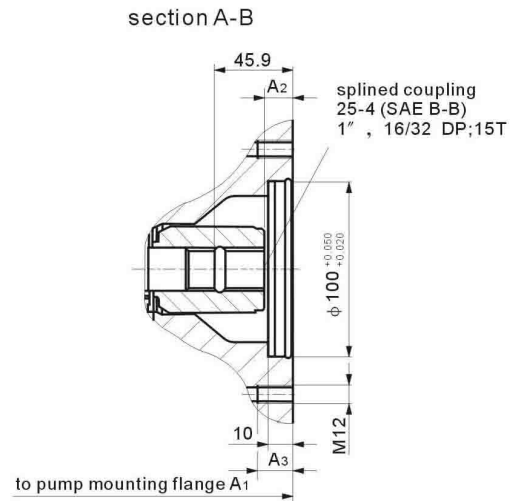

Installation Dimensions Through Drives KB5 And KB6

Flange ISO 125, 2-hole for built-on HAVSO 71 (splined S or R)
Order code KB5

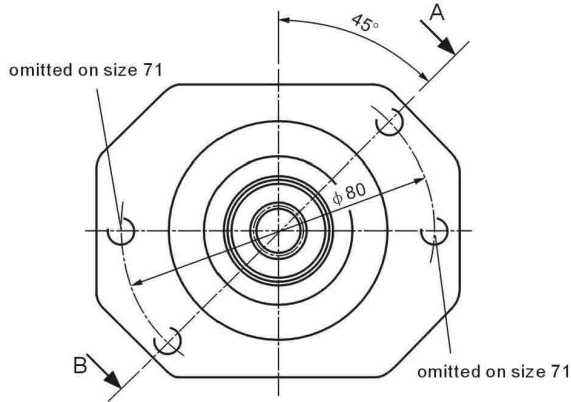

section A-B

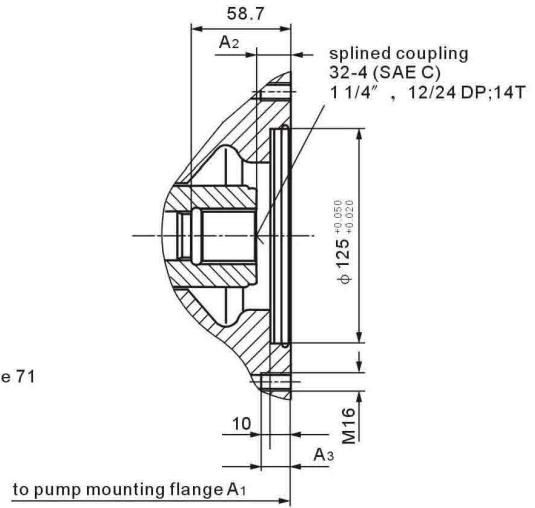

Size main pump	A ₁	A ₂	A ₃
71	267	20	18.5
100	338	20	25
140	350	21	32

Flange ISO 125, 2-hole for built-on HA10VSO 100 (splined shaft S)
Order code KB6

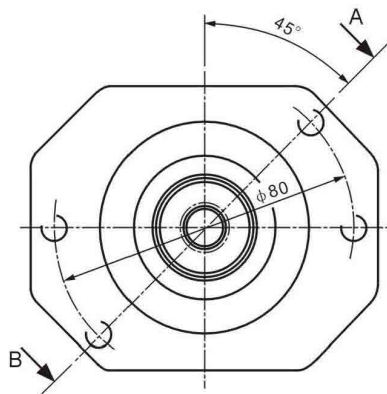

section A-B

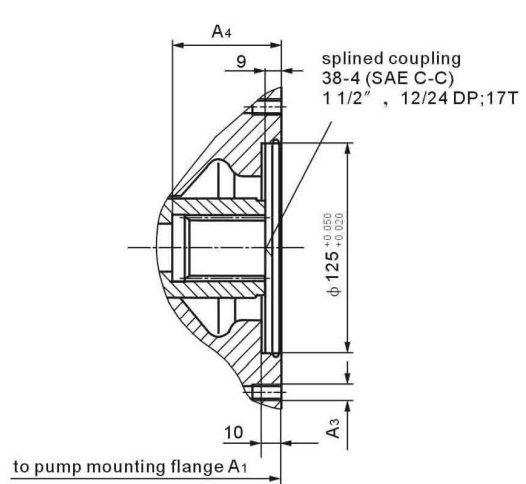

Size main pump	A ₁	A ₃	A ₄
100	338	M16; 25 deep	65
140	350	M16; 32 deep	77.3